

APA 20/30 APA 20/40

ADD-ON COMPACTORS



SMALL AND AGILE

The APA 20/30 and APA 20/40 are Ammann's smallest Add-On Compactors. They are used for garden construction and landscaping with mini-excavators in the 3- to 5-tonne weight category. They are equipped with a high-frequency, low-amplitude twin-shaft exciter that protects the excavator and nearby buildings from vibration. These Add-On Compactors can be installed in just a few steps.

PATENTED VIBRATION LIMITATION

- High-resistance rubber shock absorbers cushion vibrations to protect the excavator and the operator

TWIN-SHAFT EXCITER

- High frequency and low amplitude to protect adjacent buildings
- Maintenance-free

SAFETY

- For work on steep inclines where compaction with a vibratory plate is not safe
- Trench compaction from a safe distance

THE MACHINE THAT MATCHES

- The Add-On Compactor is compatible with all commonly used fast change systems
- With the matching fast change system, the Add-On Compactor is connected and ready to operate within a few seconds
- Mechanical and hydraulic rotators are available

RUGGED DESIGN

- The housing protects the central exciter unit
- Bearing bushings protect the housing against vibrations and prevent direct contact by metal surfaces under high pressure

APPLICATIONS

- Add-On Compactors for excavators in the 3- to 5-tonne class
- Pipeline and canal construction
- Slope and hillside compaction
- Confined work spaces, manhole compaction
- Structure backfill work
- Landfill
- Track construction

TECHNICAL SPECIFICATIONS
 APA 20/30, 20/40 ADD-ON COMPACTORS

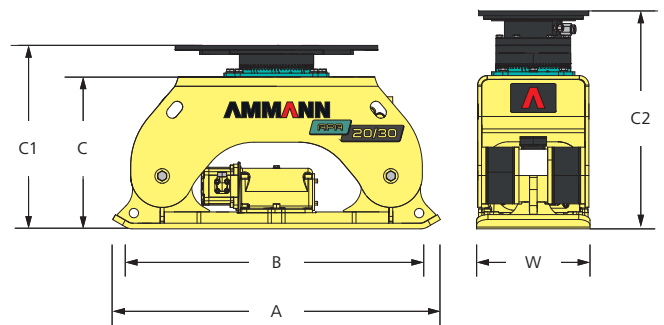

WEIGHT & DIMENSIONS

	APA 20/30	APA 20/40
MACHINE WEIGHT	160 kg (353 lb)	170 kg (375 lb)
MACHINE WEIGHT (MECH.)	185 kg (408 lb)	195 kg (430 lb)
MACHINE WEIGHT (HYD.)	230 kg (507 lb)	240 kg (529 lb)
A LENGTH	875 mm (34.4 in)	875 mm (34.4 in)
B BASE PLATE LENGTH	790 mm (31.1 in)	790 mm (31.1 in)
C HEIGHT	405 mm (15.9 in)	405 mm (15.9 in)
C1 HEIGHT (MECH.)	485 mm (19.1 in)	485 mm (19.1 in)
C2 HEIGHT (HYD.)	645 mm (25.4 in)	645 mm (25.4 in)
W WIDTH	300 mm (11.8 in)	400 mm (15.7 in)
DIAMETER	910 mm (35.8 in)	910 mm (35.8 in)
RECOMMENDED CARRIER SIZE	3 - 5 t (6614 - 11 023 lb)	3 - 5 t (6614 - 11 023 lb)

COMPACTION FORCES

MAX. VIBRATION FREQUENCY	60 Hz (3600 VPM)	60 Hz (3600 VPM)
MAX. CENTRIFUGAL FORCE	20 kN (4496 lbf)	20 kN (4496 lbf)
SPEC. SURFACE PRESSURE	8,4 N/cm ² (12.2 psi)	6,3 N/cm ² (9.2 psi)

MISCELLANEOUS

	Forward - Return	Forward - Return
HYDRAULIC CONNECTIONS		
REQUIRED HYDRAULIC PRESSURE	100 bar (1450.4 psi)	100 bar (1450.4 psi)
REQUIRED VOLUME FLOW	60 l/min (3661 in ³ /min)	60 l/min (3661 in ³ /min)
MAX. RETURN PRESSURE	30 bar (435.1 psi)	30 bar (435.1 psi)



STANDARD EQUIPMENT

- Twin-shaft exciter with high frequency and low amplitude
- Rubber cushions that protect the excavator against vibrations
- Universal adapter plate for fast changes

OPTIONAL EQUIPMENT

- Version with mechanical rotator
- Version with hydraulic rotator

For additional product information and services please visit:
www.ammann.com

Materials and specification data are subject to change without notice.
 MSS-1066-02-EN | © Ammann Group

AMMANN