

AFW 600-3

WHEELED ASPHALT PAVER LARGE CLASS, PREMIUM

EU Stage V / U.S. EPA Tier 4f

EU Stage IIIA / U.S. EPA Tier 3



MANOEUVRABLE AND HIGHLY PRODUCTIVE

The AFW 600-3 is a wheeled paver that features the latest technology to help paving contractors be productive, efficient – and ultimately profitable. The intelligent control system enables thorough monitoring of the paver. The user interface utilises an intuitive dashboard that makes the technology accessible to operators. Four-wheel drive helps the paver overcome challenging grades and underfoot conditions. A closed cab is optional available.

ADVANCED TECHNOLOGY

- Pavemanager 2.0 System monitors paving parameters in real time
- Crown and slope automatic programming
- Memory system (SetAssist Option) saves settings of screed, auger and leveling position while paving
- Efficient drive concept reduces operation costs

SUPERIOR SCREED TECHNOLOGY

- Tamper/vibration screeds
- Gas or electric heating
- 7.5 m maximum working width
- Stability through 4-tube principle
- Easy adjustment of the angle of attack
- Single crank to adjust height and side shield angle

TRACTION AND MOBILITY

- Special system analyses hopper loads and optimises traction of front wheels
- Pendulum axle in front wheels ensure constant ground contact
- Four-wheel drive provides power and traction
- Travel speed up to 20 km/h

MATERIAL FEEDING

- Large capacity hopper for reduced segregation
- Hydraulic front hopper flap (option)
- Two 655 mm independent, reversible conveyor belts
- Slim auger gearbox
- Ultrasonic sensors for auger control

APPLICATIONS

- National roads
- Highways
- Country roads
- City/municipal streets
- Building lots
- Large squares and courtyards

AMMANN

TECHNICAL SPECIFICATIONS
AFW 600-3
WHEELED ASPHALT PAVER
LARGE CLASS, PREMIUM

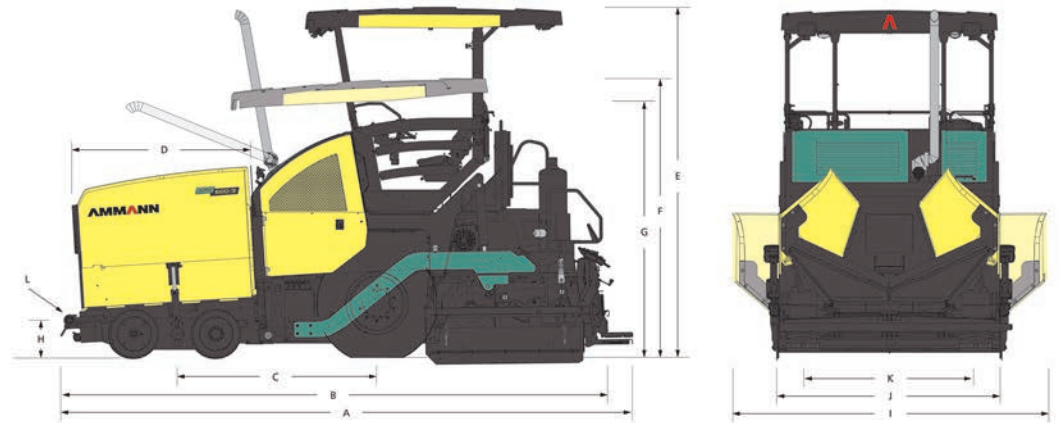

WEIGHT & DIMENSIONS

WEIGHT (INCLUDING STANDARD SCREED)	18 000 kg
A MACHINE LENGTH	6380 mm
B TRANSPORT LENGTH	6100 mm
C WHEEL BASE	2240 mm
D HOPPER LENGTH	2120 mm
E MACHINE HEIGHT	3900 mm
F TRANSPORT HEIGHT	3100 mm
G HEIGHT (W.O. CANOPY)	2845 mm
H MATERIAL LOADING HEIGHT	490 mm
I MACHINE, OPEN HOPPERS WIDTH	3250 mm
J TRANSPORT WIDTH	2550 mm
K TRACK GAUGE WIDTH	2055 mm
L MAX. APPROACH ANGLE	17° (front) / 16° (back)

CAPACITY & PERFORMANCE

PLACEMENT THICKNESS (MAX.)	300 mm
THEORETICAL PAVING CAPACITY	700 t/h
PAVING SPEED (MAX.)	30 m/min
TRANSPORT SPEED (MAX.)	20 km/h

WHEEL DRIVE

REAR WHEELS	2 × 445 / 80 R25
FRONT WHEELS	4 × 560 / 390-300
TRACTION	4WD (2 × rear wheels, 2 × front wheels)
TURNING RADIUS	2480 mm (inside) 6070 mm (outside)

SCREED OPTIONS

	STV 5100 G	STV 5100 E	STV 6000 G	STV 6000 E
BASIC WIDTH	2.55 m	2.55 m	3.00 m	3.00 m
HYDRAULIC EXTENDED WIDTH	5.10 m	5.10 m	6.00 m	6.00 m
MAX. WORKING WIDTH	7.30 m	7.30 m	7.50 m	7.50 m
CROWN RANGE	-2.5% to +4.5%	-2.5% to +4.5%	-2.5% to +4.5%	-2.5% to +4.5%
HEATING SYSTEM	Gas (LPG)	Electric	Gas (LPG)	Electric
SCREED TYPE	Tamper & vibration screed	Tamper & vibration screed	Tamper & vibration screed	Tamper & vibration screed

MATERIAL FEEDING SYSTEM

HOPPER CAPACITY	13 t
HOPPER DUMPING HEIGHT CENTER (W. HOPPER FLAP)	575 mm
HOPPER WIDTH, INTERNAL	3140 mm
CONVEYOR TYPE	Dual bar feeder
CONVEYOR WIDTH	2 × 580 mm
CONVEYOR CONTROL	Automatic with limit switches
AUGER DIAMETER	380 mm
AUGER CONTROL	Automatic with ultrasonic sensors
AUGER HEIGHT ADJUSTMENT	250 mm (hydraulic)

ENGINE

ENGINE MODEL	Cummins QSB 6.7 - C173	Cummins B 6.7 - C173
RATED POWER @ 2200 RPM	129 kW	129 kW
EMISSIONS	EU Stage IIIA	EU Stage V
ELECTRICAL SYSTEM	24 V	
FUEL TANK CAPACITY	315 l	

OPERATOR STATION

OPERATOR CONSOLE	Slidable and tiltable control console, adjustable to any position
DASHBOARD	Pave Manager 2.0 (PLC)
PLATFORM	Slidable operator platform (500 mm left and right)
ROOF	Canopy with integrated working lights