

AFT 600-3

TRACKED ASPHALT PAVER LARGE CLASS, PREMIUM

EU Stage V / U.S. EPA Tier 4f
EU Stage IIIA / U.S. EPA Tier 3



LARGE PAVER WITH SMART FEATURES

The tracked AFT 600-3 utilises a high level of technology to help make paving more productive, efficient and profitable. The intelligent control system enables thorough monitoring of the paver. The user interface utilises an intuitive dashboard that makes the technology accessible to operators. A slidable operator platform with a control console adjustable to any position allows the operator a full process control.

ADVANCED TECHNOLOGY

- Pavemanager 2.0 System monitors paving parameters in real time
- Crown and slope automatic programming
- Memory system (SetAssist Option) saves settings of screed, auger and leveling position while paving
- Efficient drive concept reduces operation costs

TRACTION

- Long, wide tracks for optimal grip and smooth drive
- High number of rollers inside tracks improves manoeuvrability on curves
- 2.9 m track length
- 320 mm track pads specially designed for pavers

SUPERIOR SCREED TECHNOLOGY

- Multiple screed options
- Ability to utilise high-compaction screeds
- Gas or electric heating
- 9 m maximum working width with mechanical extensions
- Stability through 4-tube principle
- Easy adjustment of the angle of attack with the Flexilever
- Single crank to adjust height and side shield angle

MATERIAL FEEDING

- Large capacity hopper for reduced segregation
- Hydraulic front hopper flap (option)
- Two 655 mm independent, reversible conveyor belts
- Slim auger gearbox
- Ultrasonic sensors for auger control

APPLICATIONS

- National roads
- Highways
- Country roads
- City/municipal streets
- Building lots
- Large squares and courtyards

AMMANN

TECHNICAL SPECIFICATIONS
AFT 600-3
TRACKED ASPHALT PAVER
LARGE CLASS, PREMIUM

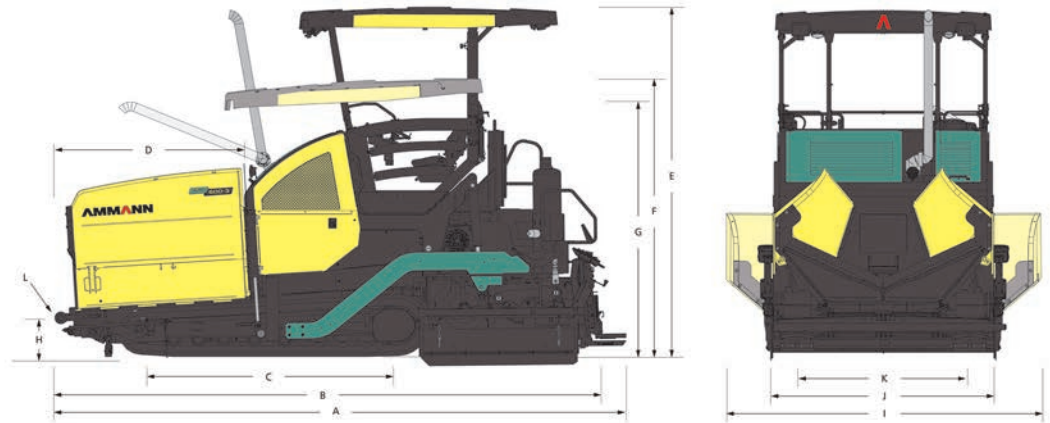

WEIGHT & DIMENSIONS

WEIGHT (INCLUDING STANDARD SCREED)	18 500 kg
A MACHINE LENGTH	6400 mm
B TRANSPORT LENGTH	6150 mm
C TRACK LENGTH	2900 mm
D HOPPER LENGTH	2120 mm
E MACHINE HEIGHT	3900 mm
F TRANSPORT HEIGHT	3100 mm
G HEIGHT (W.O. CANOPY)	2845 mm
H MATERIAL LOADING HEIGHT	490 mm
I MACHINE, OPEN HOPPERS WIDTH	3400 mm
J TRANSPORT WIDTH	2550 mm
K TRACK GAUGE WIDTH	1990 mm
L MAX. APPROACH ANGLE	15°

CAPACITY & PERFORMANCE

PLACEMENT THICKNESS (MAX.)	310 mm
THEORETICAL PAVING CAPACITY	650 t/h
PAVING SPEED (MAX.)	28 m/min
TRANSPORT SPEED (MAX.)	4 km/h

CRAWLER

CRAWLER LENGTH (AXLE TRACK)	2900 mm
CRAWLER WIDTH (PADS)	320 mm
FINAL DRIVE	Hydrostatic

SCREED OPTIONS

	STV 5100 G	STV 5100 E	STV 6000 G	STV 6000 E	STVH 5100 E	STVH 6000 E
BASIC WIDTH	2.55 m	2.55 m	3.00 m	3.00 m	2.55 m	3.00 m
HYDRAULIC EXTENDED WIDTH	5.10 m	5.10 m	6.00 m	6.00 m	5.10 m	6.00 m
MAX. WORKING WIDTH	8.80 m	8.80 m	9.00 m	9.00 m	8.10 m	9.00 m
CROWN RANGE	-2.5% to +4.5%	-2.5% to +4.5%	-2.5% to +4.5%	-2.5% to +4.5%	-2.5% to +4.5%	-2.5% to +4.5%
HEATING SYSTEM	Gas (LPG)	Electric	Gas (LPG)	Electric	Electric	Electric
SCREED TYPE	Tamper & vibration screed	Tamper & vibration screed	Tamper & vibration screed	Tamper & vibration screed	High compaction screed	High compaction screed

MATERIAL FEEDING SYSTEM

HOPPER CAPACITY	13 t
HOPPER DUMPING HEIGHT CENTER (W. HOPPER FLAP)	555 mm
HOPPER WIDTH, INTERNAL	3290 mm
CONVEYOR TYPE	Dual bar feeder
CONVEYOR WIDTH	2 × 655 mm
CONVEYOR CONTROL	Automatic with limit switches
AUGER DIAMETER	380 mm
AUGER CONTROL	Automatic with ultrasonic sensors
AUGER HEIGHT ADJUSTMENT	250 mm (hydraulic)

ENGINE

ENGINE MODEL	Cummins QSB 6.7 - C173	Cummins B 6.7 - C173
RATED POWER @ 2200 RPM	129 kW	129 kW
EMISSIONS	EU Stage IIIA	EU Stage V
ELECTRICAL SYSTEM	24 V	
FUEL TANK CAPACITY	320 l	

OPERATOR STATION

OPERATOR CONSOLE	Slidable and tiltable control console, adjustable to any position
DASHBOARD	Pave Manager 2.0 (PLC)
PLATFORM	Slidable operator platform (500 mm left and right)
ROOF	Canopy with integrated working lights